



# Aircooled condensers HTC-N



Reliable performance & excellent energy yield



## Aircooled condensers NH<sub>3</sub>

## HTC-N



### General

The HTC-N aircooled condenser range includes 4 basic types with 1 to 12 fans and duties from 22 to 930 kW at 15 K temperature difference.

### Design

Coil block	: Stainless steel tubing with aluminium fins.
Tube diameter	: 13 mm
Tube pitch	: 50 x 50 mm triangle
Fin spacing	: 2.25 mm

Other fin spacings up to 4 mm available on request.

Coil blocks are pressure tested at 28 bar dry air.

Casing and framework are of pregalvanized sheet steel (Sendzimir) with an epoxy coating on both sides. Colour scheme: light-grey RAL 7035, mounting feet models 076, 090, 091 and 100, dark-grey RAL 7016. Other colours are available at an extra price. All condensers are provided with removable header panels.

#### Condenser models 076, 090, 091 and 100

Floating construction of the condenser coil block. On request the condensers can be fitted with inspection hatches (extra price).

### Air direction

Condensers type HTC-N can be supplied for horizontal or vertical air flow.

#### Condenser models 076, 090, 091 and 100 :

standard vertical air flow.

On request also available for horizontal air flow.

When ordering without air flow indication, the standard execution will be supplied.

### Corrosion protection

The standard condensers have a high corrosion resistance through selected materials, surface treatment and construction. For application in aggressive surroundings (coastal and industrial areas) following designs are available at an extra charge:

- fins of seawater resistant aluminium alloy (57S/5052)
- fins of prepainted aluminium
- finned coils coated after assembling

# Aircooled condensers NH<sub>3</sub>

# HTC-N

## Contents

Page	
3	General information
4 - 11	Nominal duty air flow, sound levels technical data, dimensions
12	Fan types Fan motors
13	Capacity calculation Correction factors
14	Extended feet Additional information

### Construction based on HTC

HTC-N air cooled condensers are identical in construction to type HTC air cooled condensers. These condensers HTC are tested and certified by Eurovent according to ENV 327 European standard.

This extensive testing procedure comprises :

- capacities under standardised conditions
- fan capacities
- air flow data
- sound levels

### Type indication

Example : **HTC-N 076 . 124 - 930**

**HTC-N** : Aircooled condenser with St/Al coil block

**076** : Condenser type  
There are 4 basic types with different fan diameters

**1••** : Number of separated coils

**•2•** : Number of fans per coil

**••4** : Number of tube rows in air direction

**930** : Fan speed

# Aircooled condensers NH<sub>3</sub>

# HTC-N

## Capacities HTC-N ... . 1..

Type	Capacity kW		Airflow m <sup>3</sup> /h		dB(A)	Capacity kW		Airflow m <sup>3</sup> /h		dB(A)	Capacity kW		Airflow m <sup>3</sup> /h		dB(A)
	H	L	H	L		H/L	H	L	H		L	H/L	H	L	
<b>HTC-N 090</b>	<b>n = 850 / 610 rpm</b>					<b>n = 680 / 520 rpm</b>					<b>n = 860 / 660 rpm</b>				
090 . 112 - ...	60.6	51.3	30700	22700	56/49	52.3	43.6	23400	17200	51/45	49.9	43.0	21700	16900	53/47
090 . 113 - ...	79.5	66.1	28500	21100	56/49	66.7	54.6	21400	15900	51/45	65.2	53.7	20700	15500	53/47
090 . 114 - ...	86.9	70.4	26600	19800	56/49	70.4	63.6	19800	14800	51/45	70.4	62.1	19800	14400	53/47
090 . 122 - ...	122.5	103.5	61500	45400	59/52	105.3	87.8	46900	34400	54/48	100.6	86.5	43300	33700	56/50
090 . 123 - ...	160.7	133.0	57000	42200	59/52	134.3	117.4	42800	31800	54/48	131.2	115.5	41400	31000	56/50
090 . 124 - ...	174.8	157.9	53300	39600	59/52	157.6	127.8	39500	29600	54/48	157.6	125.1	39500	28900	56/50
090 . 132 - ...	191.0	161.8	92200	68000	61/54	165.0	137.6	70300	51600	56/50	157.4	135.6	65000	50600	58/52
090 . 133 - ...	242.0	200.1	85400	63300	61/54	202.0	164.9	64100	47800	56/50	197.3	161.8	62100	46600	58/52
090 . 134 - ...	273.6	237.7	79900	59500	61/54	267.2	191.9	59300	44400	56/50	237.2	187.7	59300	43300	58/52
090 . 142 - ...	246.4	207.7	122900	90700	62/55	211.9	176.0	93800	68800	57/51	201.9	173.3	86600	67400	59/53
090 . 143 - ...	310.7	284.7	113900	84500	62/55	287.3	236.3	85500	63700	57/51	280.8	232.1	82800	62100	59/53
090 . 144 - ...	388.7	317.2	106500	79300	62/55	317.1	256.3	79000	59200	57/51	317.1	250.7	79000	57700	59/53
090 . 152 - ...	327.1	277.8	153700	113400	63/56	283.2	236.7	117200	86000	58/52	270.3	233.3	108300	84300	60/54
090 . 153 - ...	415.4	344.0	142400	105600	63/56	347.3	284.0	106900	79600	58/52	339.3	278.8	103500	77600	60/54
090 . 154 - ...	470.4	381.8	133200	99100	63/56	381.1	307.5	98800	74000	58/52	381.1	324.0	98800	72100	60/54
<b>HTC-N 091</b>	<b>n = 850 / 610 rpm</b>					<b>n = 680 / 520 rpm</b>					<b>n = 860 / 660 rpm</b>				
091 . 112 - ...	62.3	58.5	32200	23700	56/49	60.1	49.9	24900	18100	51/45	56.4	49.3	22300	17700	53/47
091 . 113 - ...	79.3	75.7	30300	22400	56/49	78.7	63.0	23800	17000	51/45	73.7	62.1	21500	16600	53/47
091 . 114 - ...	101.4	82.3	28700	21200	56/49	83.2	66.5	21600	16000	51/45	80.9	65.4	20800	15600	53/47
091 . 122 - ...	139.6	118.0	64300	47400	59/52	121.4	100.5	49800	36300	54/48	113.6	99.2	44500	35400	56/50
091 . 123 - ...	184.2	152.6	60600	44700	59/52	158.8	126.6	47700	33900	54/48	148.4	124.6	43000	33100	56/50
091 . 124 - ...	204.1	165.1	57400	42500	59/52	167.1	146.6	43100	32100	54/48	162.4	143.9	41600	31300	56/50
091 . 132 - ...	187.7	182.8	96500	71100	61/54	187.9	156.1	74700	54400	56/50	176.1	154.0	66800	53100	58/52
091 . 133 - ...	277.4	229.4	90800	67100	61/54	238.9	190.1	71500	50900	56/50	223.1	187.3	64400	49700	58/52
091 . 134 - ...	316.4	256.5	86100	63700	61/54	259.5	220.3	64700	48100	56/50	252.6	216.1	62400	46900	58/52
091 . 142 - ...	281.0	237.0	128600	94800	62/55	243.9	201.6	99600	72600	57/51	228.2	198.9	89000	70800	59/53
091 . 143 - ...	359.8	296.1	121100	89500	62/55	308.6	267.8	95400	67900	57/51	287.9	264.0	85900	66200	59/53
091 . 144 - ...	409.2	330.8	114700	85000	62/55	334.6	276.3	86300	64100	57/51	355.5	288.7	83200	62600	59/53
091 . 152 - ...	345.1	290.3	160800	118500	63/56	298.7	266.7	124500	90700	58/52	300.4	263.2	111300	88500	60/54
091 . 153 - ...	440.7	391.6	151400	111800	63/56	407.9	325.3	119200	84900	58/52	381.4	320.4	107400	82800	60/54
091 . 154 - ...	540.5	438.9	143400	106200	63/56	444.2	356.2	107800	80200	58/52	431.9	349.2	104000	78200	60/54
<b>HTC-N 100</b>	<b>n = 670 / 520 rpm</b>					<b>n = 420 / 310 rpm</b>					<b>n = 380 / 250 rpm</b>				
100.112 - ...	55.1	45.4	27400	19900	59/47	51.4	40.6	19000	13500	42/34	47.6	34.0	17000	10800	39/29
100.113 - ...	69.9	56.0	25100	18100	59/47	63.2	50.0	16700	11700	42/34	57.0	39.9	14500	9000	39/29
100.114 - ...	87.7	66.9	23300	16200	59/47	70.6	-	14300	-	42	61.5	-	13000	-	39
100.122 - ...	110.7	91.2	54700	39900	62/50	103.5	81.6	38000	27000	45/37	95.7	75.2	34000	21600	42/32
100.123 - ...	140.1	112.1	50100	36200	62/50	114.4	100.4	33400	23400	45/37	121.2	79.9	29000	18000	42/32
100.124 - ...	176.0	134.1	46500	32300	62/50	142.2	-	28600	-	45	123.7	-	26000	-	42
100.132 - ...	166.2	137.0	82100	59800	64/52	160.7	127.1	57000	40500	47/39	148.7	113.2	51000	32400	44/34
100.133 - ...	210.4	168.2	75200	54300	64/52	190.8	141.8	50100	35100	47/39	172.0	115.7	43500	27000	44/34
100.134 - ...	272.0	207.5	69800	48500	64/52	213.3	-	42900	-	47	185.3	-	39000	-	44
100.142 - ... *	222.0	182.7	109500	79700	65/53	207.6	179.0	76000	54000	48/40	191.9	151.0	68000	43200	45/35
100.143 - ...	311.7	249.4	100200	72400	65/53	269.0	201.7	66800	46800	48/40	243.1	160.3	58000	36000	45/35
100.144 - ...	353.1	268.7	93100	64700	65/53	284.9	-	57200	-	48	247.4	-	52000	-	45
100.152 - ... *	301.2	249.4	136900	99600	66/54	220.3	191.9	95000	67500	49/41	254.4	182.7	85000	54000	46/36
100.153 - ... *	382.8	305.8	125300	90500	66/54	327.0	243.1	83500	58500	49/41	294.6	206.4	72500	45000	46/36
100.154 - ...	463.6	354.0	116300	80800	66/54	343.7	-	71500	-	49	299.2	-	65000	-	46

H = High fan speed

L = Low fan speed

Note : Actual fan speed may differ from the values as indicated on the motor name plate.

## Aircooled condensers NH<sub>3</sub>

## HTC-N

### Technical Data HTC-N ●● . 1●●

Type	Refrigerant conn. mm		Int. vol. dm <sup>3</sup>	Sur-face m <sup>2</sup>	Weight kg	Dimensions mm			
	in	out				A	B	C	D
<b>HTC-N 076 n = 930 rpm</b>									
076.112-...	1x26.9	1x26.9	7	103	137				
076.113-...	1x26.9	1x26.9	11	154	160	2000	see page 15	1x1400	
076.114-...	1x26.9	1x26.9	14	205	183				
076.122-...	1x33.7	1x26.9	13	205	269				
076.123-...	1x33.7	1x26.9	20	308	314	3400	see page 15	2x1400	
076.124-...	1x33.7	1x26.9	26	410	358				
076.132-...	1x33.7	1x26.9	20	308	406				
076.133-...	1x42.4	1x26.9	31	461	474	4800	see page 15	3x1400	
076.134-...	1x42.4	1x33.7	41	615	542				
076.142-...	1x42.4	1x33.7	26	410	539				
076.143-...	1x42.4	1x33.7	39	615	628	6200	see page 15	4x1400	
076.144-...	1x48.3	1x33.7	52	820	718				
076.152-...	1x42.4	1x33.7	32	513	671				
076.153-...	1x48.3	1x42.4	48	769	782	7600	see page 15	5x1400	
076.154-...	1x60.3	1x42.4	64	1025	893				
076.162-...	1x48.3	1x33.7	38	615	804				
076.163-...	1x60.3	1x42.4	57	923	936	9000	see page 15	6x1400	
076.164-...	1x60.3	1x42.4	76	1230	1068				

### HTC-N 090 n = 850 / 610 rpm

090.112-...	1x26.9	1x26.9	9	123	241				
090.113-...	1x33.7	1x26.9	13	185	269	2000	see page 15	1x1400	
090.114-...	1x33.7	1x26.9	17	246	297				
090.122-...	1x42.4	1x26.9	16	246	477				
090.123-...	1x42.4	1x33.7	23	369	531	3400	see page 15	2x1400	
090.124-...	1x42.4	1x33.7	31	492	584				
090.132-...	1x42.4	1x33.7	24	369	718				
090.133-...	1x48.3	1x33.7	37	554	800	4800	see page 15	3x1400	
090.134-...	1x48.3	1x42.4	49	738	882				
090.142-...	1x48.3	1x33.7	31	492	955				
090.143-...	1x60.3	1x42.4	47	738	1062	6200	see page 15	4x1400	
090.144-...	1x60.3	1x42.4	63	984	1169				
090.152-...	1x60.3	1x42.4	38	615	1191				
090.153-...	1x76.1	1x48.3	58	923	1324	7600	see page 15	5x1400	
090.154-...	1x76.1	1x48.3	77	1230	1457				

### Technical Data HTC-N ●● . 1●●

Type	Refrigerant conn. mm		Int. vol. dm <sup>3</sup>	Sur-face m <sup>2</sup>	Weight kg	Dimensions mm			
	in	out				A	B	C	D
<b>HTC-N 091 n = 850 / 610 rpm</b>									
091.112-...	1x26.9	1x26.9	10	152	264				
091.113-...	1x33.7	1x26.9	16	229	298	2350	see page 15	1x1750	
091.114-...	1x33.7	1x26.9	21	305	332				
091.122-...	1x42.4	1x26.9	21	305	528				
091.123-...	1x42.4	1x33.7	31	459	597	4100	see page 15	2x1750	
091.124-...	1x42.4	1x33.7	42	610	666				
091.132-...	1x42.4	1x33.7	30	457	787				
091.133-...	1x48.3	1x42.4	44	688	888	5850	see page 15	3x1750	
091.134-...	1x60.3	1x42.4	59	915	989				
091.142-...	1x48.3	1x42.4	38	610	1046				
091.143-...	1x60.3	1x42.4	58	917	1179	7600	see page 15	4x1750	
091.144-...	1x60.3	1x42.4	77	1219	1312				
091.152-...	1x60.3	1x42.4	47	762	1305				
091.153-...	1x76.1	1x48.3	71	1147	1470	9350	see page 15	5x1750	
091.154-...	1x76.1	1x48.3	94	1524	1635				
<b>HTC-N 100 n = 670 / 520 rpm</b>									
100.112-...	1x26.9	1x26.9	10	152	264				
100.113-...	1x33.7	1x26.9	16	229	298	2350	see page 15	1x1750	
100.114-...	1x33.7	1x26.9	21	305	332				
100.122-...	1x42.4	1x26.9	21	305	528				
100.123-...	1x42.4	1x33.7	31	459	597	4100	see page 15	2x1750	
100.124-...	1x42.4	1x33.7	42	610	666				
100.132-...	1x42.4	1x33.7	30	457	787				
100.133-...	1x48.3	1x42.4	44	688	888	5850	see page 15	3x1750	
100.134-...	1x60.3	1x42.4	59	915	989				
100.142-...	1x48.3	1x42.4	38	610	1046				
100.143-...	1x60.3	1x42.4	58	917	1179	7600	see page 15	4x1750	
100.144-...	1x60.3	1x42.4	77	1219	1312				
100.152-...	1x60.3	1x42.4	47	762	1305				
100.153-...	1x76.1	1x48.3	71	1147	1470	9350	see page 15	5x1750	
100.154-...	1x76.1	1x48.3	94	1524	1635				
<b>HTC-N 100 n = 420 / 310 rpm</b>									
100.112-...	1x26.9	1x26.9	10	152	264				
100.113-...	1x33.7	1x26.9	16	229	298	2350	see page 15	1x1750	
100.114-...	1x33.7	1x26.9	21	305	332				
100.122-...	1x42.4	1x26.9	21	305	528				
100.123-...	1x42.4	1x33.7	31	459	597	4100	see page 15	2x1750	
100.124-...	1x42.4	1x33.7	42	610	666				
100.132-...	1x42.4	1x33.7	30	457	787				
100.133-...	1x48.3	1x42.4	44	688	888	5850	see page 15	3x1750	
100.134-...	1x60.3	1x42.4	59	915	989				
100.142-...	1x48.3	1x42.4	38	610	1046				
100.143-...	1x60.3	1x42.4	58	917	1179	7600	see page 15	4x1750	
100.144-...	1x60.3	1x42.4	77	1219	1312				
100.152-...	1x60.3	1x42.4	47	762	1305				
100.153-...	1x76.1	1x48.3	71	1147	1470	9350	see page 15	5x1750	
100.154-...	1x76.1	1x48.3	94	1524	1635				

# Aircooled condensers NH<sub>3</sub>

# HTC-N

HTC-N 076 . 1••

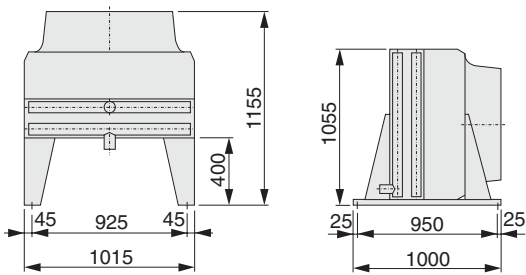

HTC-N 090 . 1••

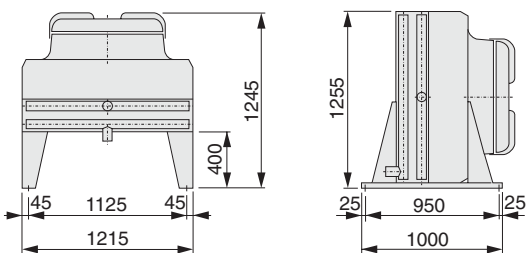

HTC-N 091 / 100 . 1••

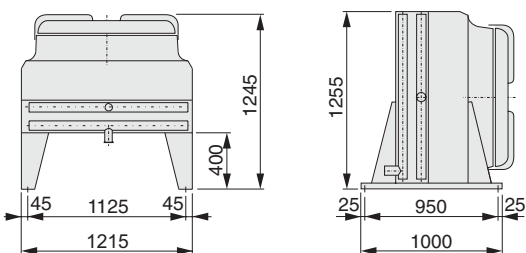

HTC-N 076 / 090 / 091 / 100 . 1••  
Vertical Air Direction

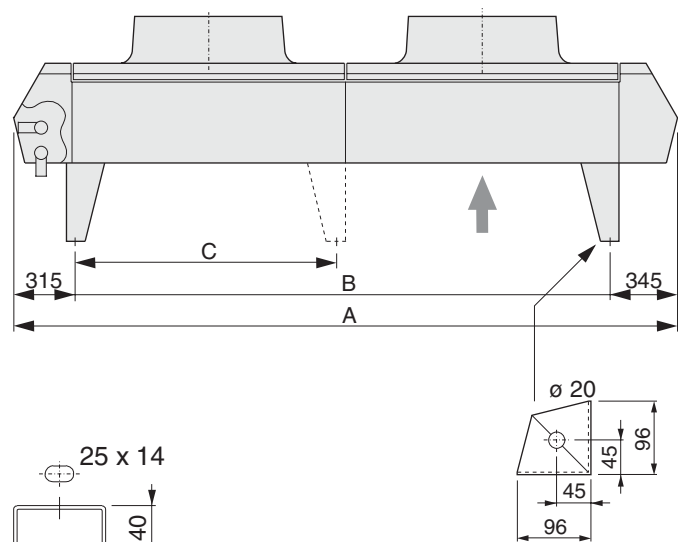

HTC-N 076 / 090 / 091 / 100 . 1••  
Horizontal Air Direction

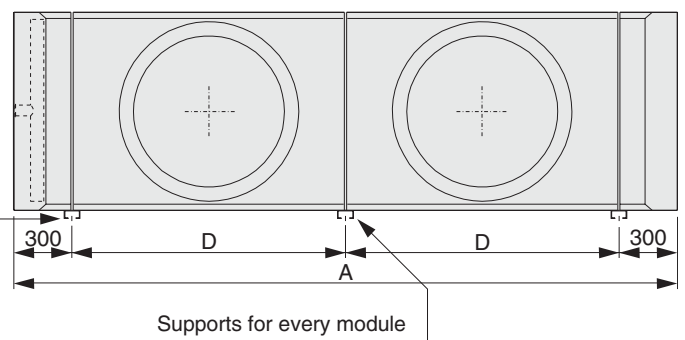

## Aircooled condensers NH<sub>3</sub>

## HTC-N

### Fan types

All fan types have corrosion resistant fan blades and fan guards.

#### HTC-N Type 076

Fans ø 762 mm mounted on a motor support.  
Fan guards are integrated in the fan plate.  
Standard execution with fan motors type 076.930.  
Motors are wired to one or more common terminal boxes.

The terminal boxes are located on the endplate at the liquid header end of the coil.

#### HTC-N Type 090 / 091

Fans ø 900 mm with 2-speed fan motors integrated with guards and mounted to fan discharge hood.

#### HTC-N Type 100

Similar in construction to type 090 / 091, fan diameter however 1000 mm.

All fan motors of HTC-N models **090**, **091** and **100** are equipped with an overload protector built in the windings. Via terminals in the terminal box this internal protector **must** be used in the control current circuit. The electrical control should be arranged in such a way that continuous on/off switching of the motors ('tripping') is prevented.  
When the condensers are out of use for longer periods, the motors have to be switched on for at least 2 hours every month.

#### All Models

For application at ambient temperatures above 40 °C : special motors on request.

### Fan motors

Motor type	Number of poles	rpm	Capacity		Motor voltage Volt	Thermal overload relay settings (A) * 220 / 380
			nominal Watt	absorbed Watt		

#### HTC-N type 076 (enclosed design, IP-55)

076 . 930		6	930	750	1170	230/400/50/3	5.0 / 2.9
076 . 690		8	690	370	560	230/400/50/3	2.6 / 1.5
076 . 325		16	325	120	290	230/400/50/3	2.0 / 1.2
076 . 425	YI	6	935	750	1420	400/50/3	3.1
	YII	12	425	150	300	400/50/3	1.1
076 . 930	M	6	930	750	1170	230/50/1	8.0
076 . VAR		6	var.	750	1000	230/50/1	8.4 **
076 . 840		8	840	660	770	230-254/400-440/60/3	4.8 / 2.8

#### HTC-N type 090 (enclosed design, IP-54)

090 . 850	Δ	-	850		3300	400/50/3	6.93
	Y	-	610		1900	400/50/3	3.85
090 . 680	Δ	-	680		1750	400/50/3	3.96
	Y	-	520		1200	400/50/3	2.53
090 . 860	Δ	-	830		1600	400/50/3	3.85
	Y	-	610		910	400/50/3	1.98

#### HTC-N type 091 (enclosed design, IP-54)

091 . 850	Δ	-	850		3300	400/50/3	6.93
	Y	-	610		1900	400/50/3	3.85
091 . 680	Δ	-	680		1750	400/50/3	3.96
	Y	-	520		1200	400/50/3	2.53
091 . 860	Δ	-	830		1600	400/50/3	3.85
	Y	-	610		910	400/50/3	1.98

#### HTC-N type 100 (enclosed design, IP-54)

100 . 670	Δ	-	650		2200	400/50/3	4.6
	Y	-	460		1350	400/50/3	3.0
100 . 420	Δ	-	420		860	400/50/3	2.2
	Y	-	310		500	400/50/3	1.07
100 . 380	Δ	-	380		670	400/50/3	1.54
	Y	-	250		330	400/50/3	0.74

\* The settings can be applied to a minimum ambient temperature of -10 °C

\*\* Value at highest speed.

Note : Actual fan speed may differ from the values as indicated on the motor name plate.

## Aircooled condensers NH<sub>3</sub>

## HTC-N

### Capacity

The basic capacity ratings (pages 4, 5, 8 and 9) are for NH<sub>3</sub> at a td \* of 15 K and ambient temperatures up to 25 °C.

\* td = difference between condensing- and ambient temperature.

Capacities are directly proportional with other temperature differences between 10 and 20 K.

### Correction factors

		Factor
Ambient temperature :	25 °C	1.00
	35 °C	0.96
	40 °C	0.94
	(special motor)	50 °C
Altitude above sea level :	0 m	1.00
	500 m	0.97
	1000 m	0.93
	1500 m	0.90
	2000 m	0.86
	2500 m	0.83
Application of motors suitable for 60 Hz with n = 840 rpm		0.95

#### Example : HTC-N 076 . 124 - 60 Hz fans

What is the condenser capacity at an ambient temperature of 40 °C, refrigerant NH<sub>3</sub>, altitude at sea level and equipped with motors for 60 Hz ?

Nominal capacity at 15 K tv : 104.2 kW

Correction factors :

t = 40 °C : 0.94

altitude sea level : 1.00

60 Hz motors : 0.95

Corrected capacity :

0.94 x 1.00 x 0.95 x 104.2 = 93.0 kW

### Capacity control

For multifan models capacity can be controlled by cycling one or more fans. Capacity control on all models is also possible by using 2-speed or speed regulated single phase motors (in combination with an electronic speed control device).

The fan compartments are separated by baffle plates.

### Multi circuiting

Condensers can be supplied (at extra cost) with multi circuiting.

### Soundlevels dB(A)

The soundlevels in the tables on pages 4, 5, 8 and 9 are the results of tests in free field conditions. The values are measured in the horizontal plane at a distance of 10 m. More information on request.

The table below gives sound level corrections at various distances.

Distance m	Correction dB(A)
1	+ 20
2	+ 14
3	+ 10
4	+ 8
5	+ 6
10	0
20	- 6
50	- 14
100	- 20

## Aircooled condensers NH<sub>3</sub>

## HTC-N

### Extended feet

Extended feet can be supplied as optional extra for condenser models 076, 090, 091 and 100. These feet are supplied separately. The standard feet height gives 400 mm free space under the condenser. Extended feet are available for heights of 600 mm.

### Transport

All models are provided with lifting lugs. To avoid damage during hoisting, a hoisting beam should be used, by which the given angles are to be considered. Beware of shocks during transport and handling (sudden lifting).

### Mounting

Refrigerant pipework connections are to be soldered free of tension. When connecting more than one condenser in parallel the pressure drop on the refrigerant side has to be considered.

### Location

#### Air movement

Condensers should be positioned to achieve the following criteria :

- Adequate space (min. 1.0 meter) must be left for free entry to the coil inlet face.
- No restrictions to the air discharge.
- No possibility of direct air recirculation (short circuiting of air).

### Installation and maintenance

For more information on installation and maintenance of air cooled condensers model HTC-N we refer to our brochure nr. 88.02 ( "Installation and Maintenance Instructions for Aircooled Condensers" ). This brochure is issued with every condenser.

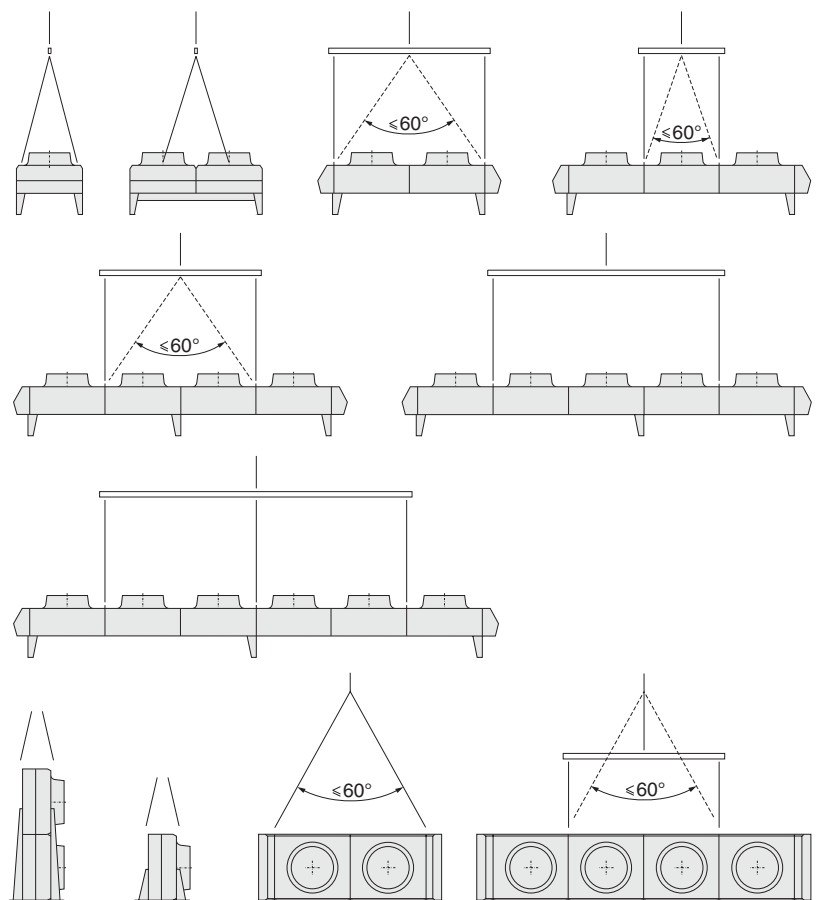

## Alfa Laval in brief

Alfa Laval is a leading global provider of specialized products and engineered solutions.

Our equipment, systems and services are dedicated to helping customers to optimize the performance of their processes. Time and time again.

We help our customers to heat, cool, separate and transport products such as oil, water, chemicals, beverages, foodstuffs, starch and pharmaceuticals.

Our worldwide organization works closely with customers in almost 100 countries to help them stay ahead.

## How to contact Alfa Laval

Up-to-date Alfa Laval contact details for all countries are always available on our website at [www.alfalaval.com](http://www.alfalaval.com)

## Helpman products

Helpman, a well respected air heat exchanger manufacturer, was acquired by Alfa Laval in 2007. The Helpman brand will remain as a strong product name.

Information about Alfa Laval Helpman products is available on the website [www.helpman.com](http://www.helpman.com).

